



PROSES ISI EKİPMANLARI SAN. VE TİC. A.Ş.



- ◆ Expert Staff
- ◆ Current Standards
- ◆ Durable Products
- ◆ Reliable Service

# General Product Catalogue

<b>ABOUT US</b> .....	3
<b>SHELL AND TUBE HEAT EXCHANGERS</b> .....	4
<b>AIR-COOLED HEAT EXCHANGERS</b> .....	5
<b>ECONOMISERS AND RECUPERATORS</b> .....	6
<b>RADIATORS</b> .....	7
<b>FINNED TUBES (SERPENTINES)</b> .....	8
<b>PRESSURE VESSELS</b> .....	9
<b>PLATE HEAT EXCHANGERS</b> .....	10
<b>BRAZED PLATE HEAT EXCHANGERS</b> .....	11

## ABOUT US

In line with its experienced engineer staff and innovative vision, ERK Proses ve Isı Ekipmanları Sanayi Ticaret A.Ş. carries out the thermal and mechanical design studies of heat exchangers such as shell and tube heat exchangers, air-cooled heat exchangers, economisers etc. and many other heat exchangers that require standard or tailor-made manufacturing in accordance with international standards.

ERK adopts as a duty to provide service to its solution partners in the manufacturing of products designed in accordance with the process in line with the relevant standards, with the shortest delivery time and competitive price policy, without sacrificing quality thanks to its specialized manufacturing team.

## OUR MISSION

Is to be one of the valuable companies of our country and the world, offering the most accurate solutions and the most up-to-date technologies in line with the benefits of its customers.

## OUR VISION

Is to develop together with its employees, who are the cornerstone of its existence, by always adopting research and development activities as a priority objective, in order to offer the most modern and dynamic solutions to the demands of our developing world by accepting -as an engineering-based company- engineering ethics as the basic line in all its products and services.

## SHELL AND TUBE HEAT EXCHANGERS

Shell and tube heat exchangers are industrial products that provide heat transfer from one fluid to another without any contact between two fluids with a temperature difference between them.

With its tailor-made manufacturing method, ERK provides service to its customers in line with its mission of shortest delivery time and competitive price policy by prioritizing quality.

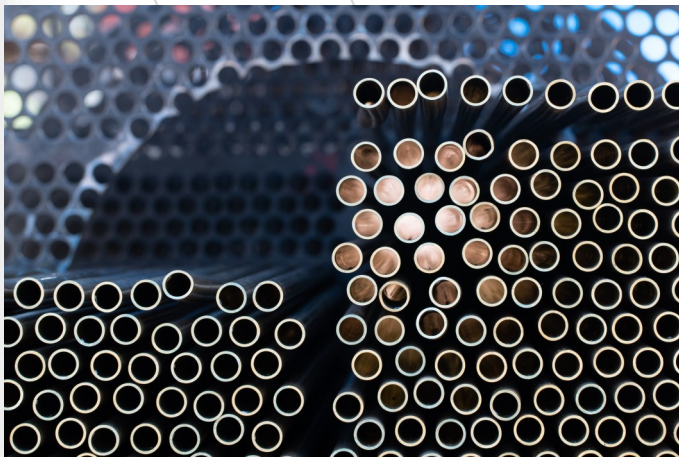

### Areas of Usage

- Food, Dairy and Beverage Industry
- Automotive Industry
- Chemical Industry
- Paper Industry
- Energy
- Biotechnology and Pharmaceutical
- Petroleum and Petrochemical
- Maritime and Transport
- Home and Personal Care
- Iron and Steel
- Mining and Mineral Industry
- Water and Waste Treatment Industry etc.

### Types of Shell and Tube Heat Exchangers

- Fixed Head Heat Exchanger
- Floating Head Heat Exchanger
- U-tube Heat Exchanger
- Jacketed Pipe Heat Exchanger
- Hairpin Heat Exchanger
- Kettle-type Heat Exchanger

### Standards

- EN 13445
- ASME Sec. VIII Div. 1 & 2
- AD-2000
- API 660
- TEMA Standards

# AIR-COOLED HEAT EXCHANGERS



Air-cooled heat exchangers are devices specially designed to transfer the heat taken from the high-temperature fluid to be cooled or condensed to the low-temperature ambient air.

Such devices are suitable for use in processes where the desired cooling can be achieved with outdoor air as a requirement of operation.

With its engineer staff specialized in its own field, ERK provides service with quality and effective products by offering air-cooled heat exchanger designs in accordance with customer requests.

## Components of Air-Cooled Heat Exchanger

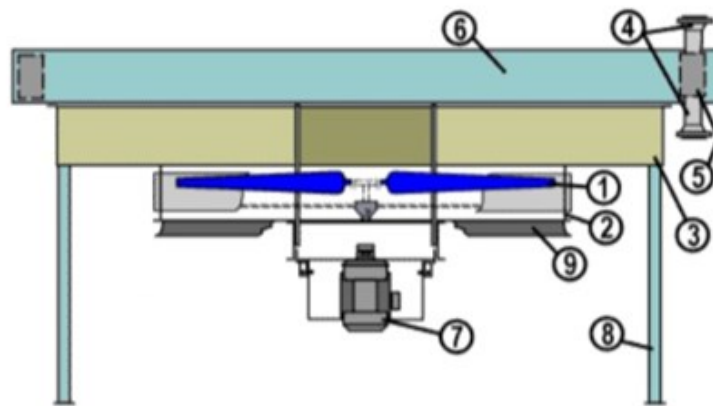

- |                                 |                       |
|---------------------------------|-----------------------|
| 1- Fan                          | 6- Tube bundle        |
| 2- Fan duct                     | 7- Fan drive unit     |
| 3- Air distribution line        | 8- Steel construction |
| 4- Inlet and outlet connections | 9- Air inlet          |
| 5- Tube bundle head             |                       |

## Collector Types

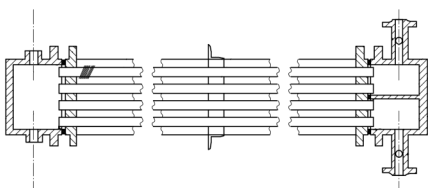

Removable (Bonnet) Collector

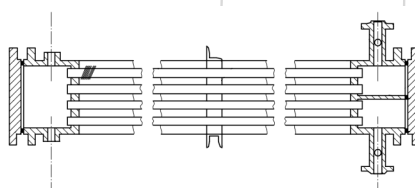

Removable Covered Collector

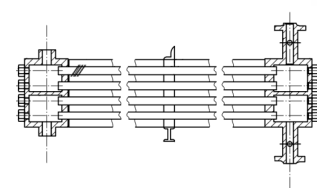

Plug-type Collector

## ECONOMISERS AND RECUPERATORS

Economisers are products that provide energy recovery from the waste heat discharged from the chimney in steam, hot oil, hot water boilers and cogeneration systems and are used for heating boiler feed water in accordance with the operational needs, in-house hot water need, as a heat source for a different device and for similar purposes.

Recuperators, on the other hand, are products used for burner air preheating, process hot air needs, drying and similar purposes needed in the business by making use of the waste heat discharged from the chimney.

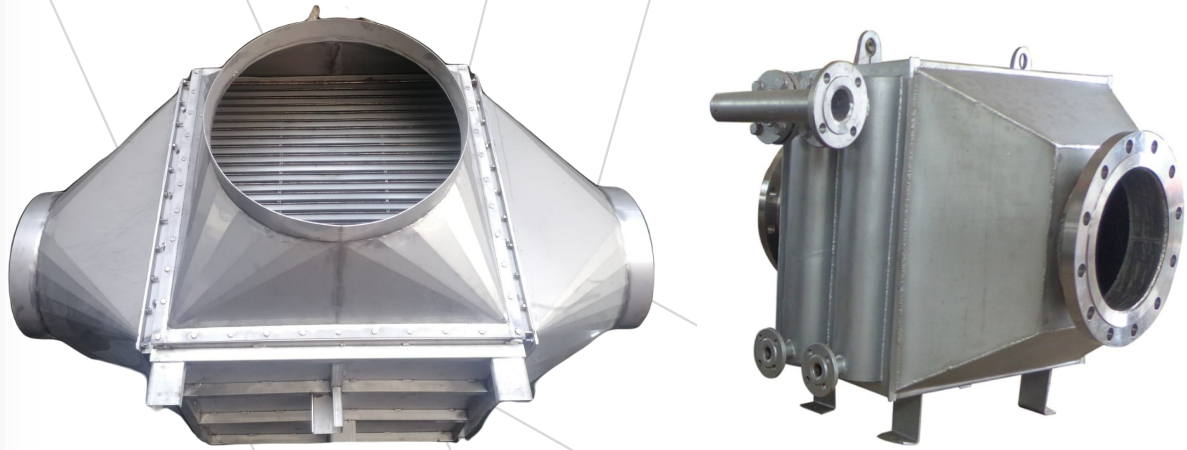

Fuel type and stack gas temperature are very important in the design of related products. They can be manufactured in two different types as condensing and non-condensing. In case of non-condensing design in natural gas fueled systems, the stack gas can be reduced to an outlet temperature of  $110^{\circ}\text{C}$  while stack gas outlet temperature can be designed up to  $50^{\circ}\text{C}$  in condensing types. In solid-liquid fuel systems (fuel-oil, coal, diesel etc.), the stack gas outlet temperature of  $130-180^{\circ}\text{C}$  in non-condensing designs varies according to the fuel type, while designs can be made at a stack gas outlet temperature of up to  $50-55^{\circ}\text{C}$  in condensing types.

ERK offers related products with proven designs, taking into account all impermeability and condensation criteria, according to customer process data. Product thermal and mechanical calculations are made in accordance with the TEMA standard and the 2014/68/EU PED pressure vessels directive. Economisers and recuperators are made of carbon steel and stainless steel, taking into account the fluid data.

## RADIATORS

Radiators are heat exchangers used to transfer heat from one environment to another for cooling or heating purposes. They are mostly manufactured from finned pipes in accordance with process conditions in order to increase thermal conductivity.

In line with the process conditions, radiators can be made entirely of carbon steel, completely stainless steel, as well as fins and pipes made of copper, bafon (Cu-Zn) and many other materials.



### Areas of Usage

- Tectile drying machines
- Ambient cooling and heating
- Hot oil, steam systems
- Geothermal facilities
- Food drying systems
- Chemical plants
- Air handling plants
- Industrial washing machines
- Heat recovery systems
- Automotive industry etc.

### Some Fluids Used

- Hot water
- Boiling water
- Sea water
- Steam
- Hot oil
- Nitrogen etc.

## FINNED TUBES (SERPENTINES)

With the fin structures added on the pipe, the heat transfer surface of the pipe is increased, resulting in a more effective heat transfer. In this way, the amount of pipes used and thus the cost are reduced and more compact product designs can be offered.

### Fin Types

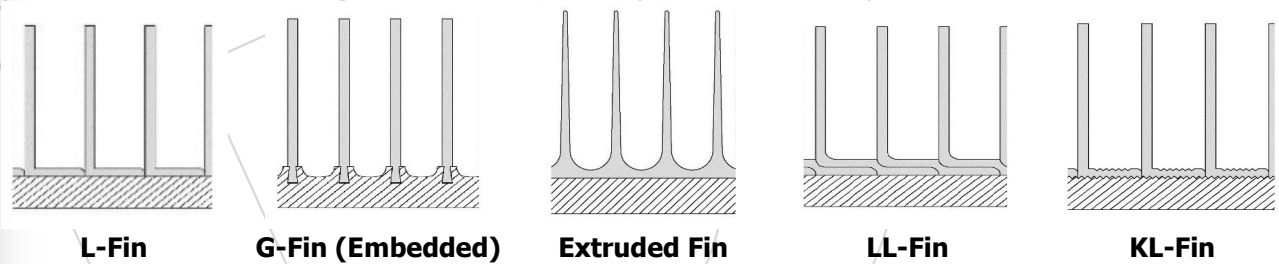

### Serpentine Types

- Spiral Finned Serpentine
- Oval Tube Serpentine
- Stamping Serpentine
- Self-finned Serpentine
- Grooved Tube



### Tube and Fin Materials

- Carbon steel
- Stainless steel
- Copper
- Brass (Cu-Zn)
- Aluminium
- DKP

### Dimensions

- Pipe Diameter: 16 - 60,3 mm
- Fin Height: 8 - 20 mm
- Pitch: 2,5 - 10 mm
- Fin Thickness: 0,4 - 1,5 mm





## PRESSURE VESSELS



Pressure vessels are products designed to store fluids or perform various process operations under a pressure different from the ambient pressure. Since the fluid contained in pressure vessels is at a different pressure than the ambient pressure, it may cause a dangerous situation, and its design and production are regulated in accordance with the relevant standards and norms.

### Standards

- ASME Sec VII Div.1
- AD 2000
- EN 13445
- API 650
- 2014/68/EU PED

### Impact Loads

- Internal and External Pressure
- **Static and Dynamic Loading**
- Temperature
- Wind
- Weight
- Vibrations

### Areas of Usage

They are frequently used in the storage of process fluids such as compressed air, hot water, raw materials, acidic fluids in chemistry, refinery, food and many other sectors.

### Used Materials

Depending on the process conditions, they are produced from stainless steel, carbon steel and alloy steel materials in different thicknesses and sizes.



## PLATE HEAT EXCHANGERS

Gasketed plate heat exchangers are equipment that provide heat transfer between fluids with two different temperatures. Between the heat transfer plates placed between two bodies, one fixed and the other movable, the fluids move in the opposite direction and leave the heat exchanger by performing heat transfer without mixing with each other. Cold fluid is on one side of the plate and hot fluid is on the other. Thanks to the gaskets located between the plates, the fluids do not mix with each other and sealing is ensured in the volume created between the plates.

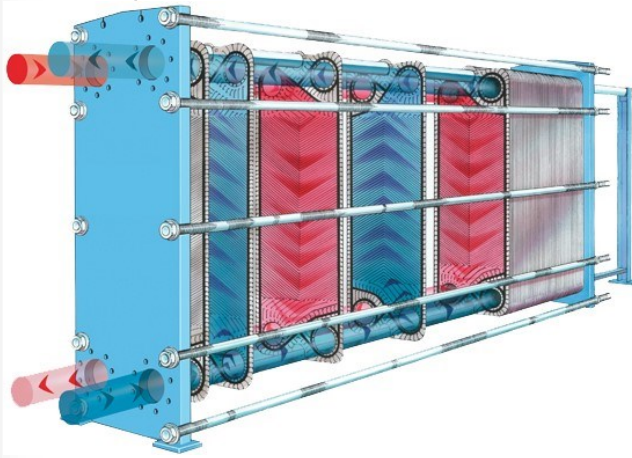

### Materials

- Body Materials:
  - Carbon steel
  - Stainless steel
  - Stainless coating
- Plate Materials:
  - AISI304
  - AISI316L
  - Titanium
  - Hastelloy alloys
- Gasket Materials:
  - NBR, HNBR
  - EPDM, EPDM-HT
  - FKMA, FKMG

### Components

- Fixed and movable body
- Heat transfer plates
- Sealing gaskets
- Upper and lower carrier and centering rods
- Stds and other fastening equipment
- Inlet-outlet port or connections
- Rear support profile
- Body fixing equipment

### Advantages

- They are suitable for use in many applications and industries.
- Capacity increase can be easily achieved by adding a plate.
- Maintenance is quite easy.
- Plaka yüzeylerindeki özel tasarımlar türbülans oluşturarak etkinliği artırırken birikinti oluşumunu azaltır.

## BRAZED PLATE HEAT EXCHANGERS



The compressed plate package of soldered plate heat exchangers is soldered with copper under vacuum at high temperature to ensure sealing. It is possible to use them at higher temperatures and pressures than conventional type gasketed plate heat exchangers. They have a more compact structure.

ERK Soldered Plate Heat Exchangers are suitable for use between  $-50^{\circ}\text{C}$  and  $+220^{\circ}\text{C}$  temperatures and 30 bar design pressure and can be used in various industries.

### Areas of Usage

- Heating Systems
- Domestic Water Systems
- Condensers and Evaporators
- Energy Recovery Systems
- Oil Coolers
- Industrial Applications etc.

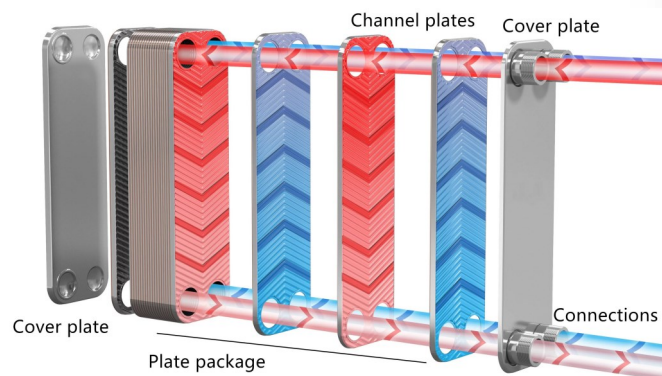

Model No	Height	Width	Distance Between Inlet and Outlet Holes	Depth	Weight
<b>HAF-17</b>	206 mm	76 mm	42 / 172 mm	9+2,3N	0,7+0,06N
<b>HAF-17A</b>	206 mm	80 mm	40 / 154 mm	9+2,3N	0,7+0,06N
<b>HAF-23</b>	315 mm	86 mm	40 / 269 mm	9+2,3N	1,0+0,08N
<b>HAF-23A</b>	315 mm	78 mm	40 / 282 mm	9+2,3N	1,0+0,08N
<b>HAF-34</b>	310 mm	111 mm	50 / 250 mm	10+2,36N	1,3+0,12N
<b>HAF-55</b>	525 mm	111 mm	50 / 466 mm	10+2,35N	2,6+0,21N
<b>HAF-88</b>	616 mm	191 mm	92 / 519 mm	11+2,72N	7,8 + 0,44N



PROSES ISI EKİPMANLARI SAN. VE TİC. A.Ş.

Şemsipaşa Mah. 10. Sok.  
Nu:28/2 Gaziosmanpaşa / İSTANBUL

Contact: +90 216 533 26 23

E-mail: [info@erkproses.com](mailto:info@erkproses.com)